





Nom – Prénom : \_\_\_\_\_

# MATHÉMATIQUES

## Géométrie et Espace CM2 - « Je m'entraîne »

JE M'ENTRAINE	COMPÉTENCE	CODE
GE12	Je repère et trace des patrons de pavé droit.	

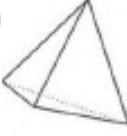
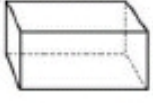
**Exercice 1 :** Associe chaque solide à son patron.

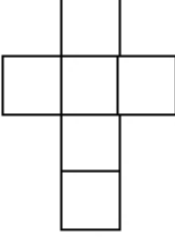
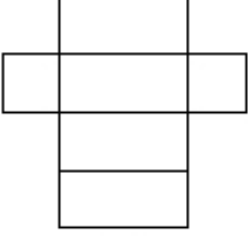
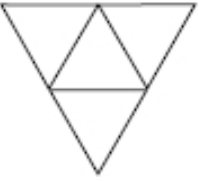
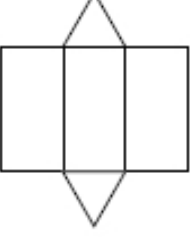
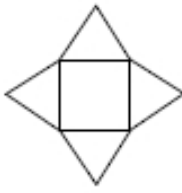
① 	② 	③ 	④ 	⑤ 
La pyramide	Le cube	Le tétraèdre	Le pavé	Le prisme
				
<input type="radio"/>	<input type="radio"/>	<input type="radio"/>	<input type="radio"/>	<input type="radio"/>

**Exercice 2 :** Aide toi du modèle et complète ce patron de pavé droit.

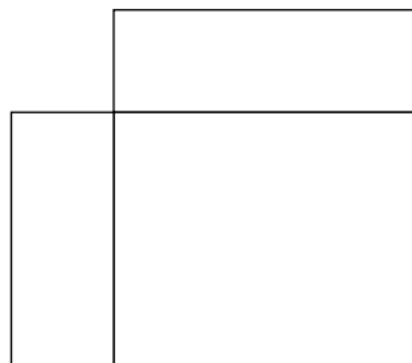
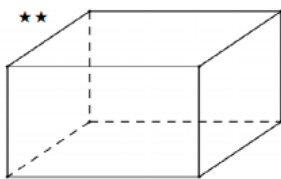

**Exercice 3 : Associe chaque pavé droit à son patron.**

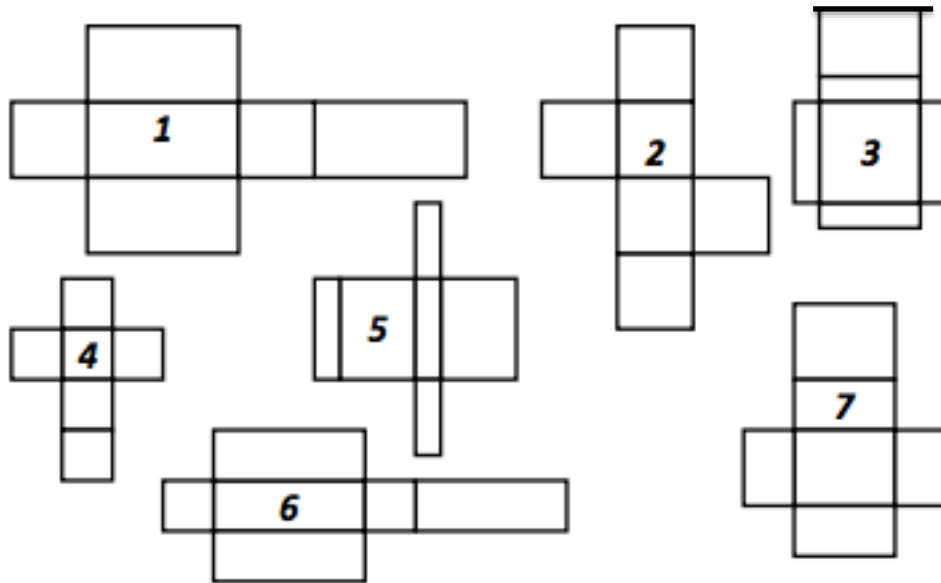

PATRON	1	2	3	4	5	6	7
SOLIDE							

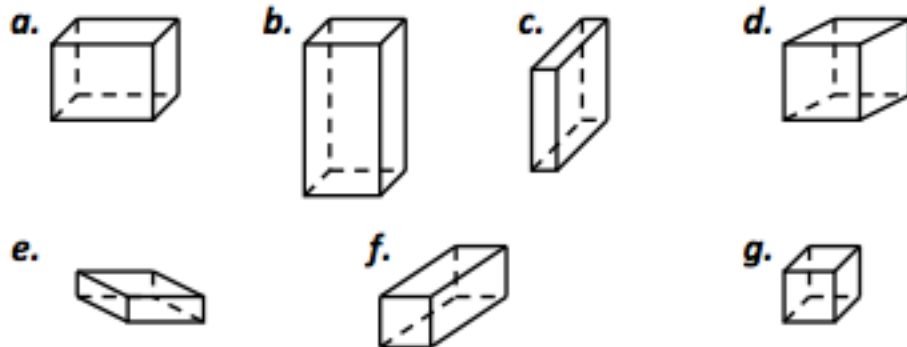



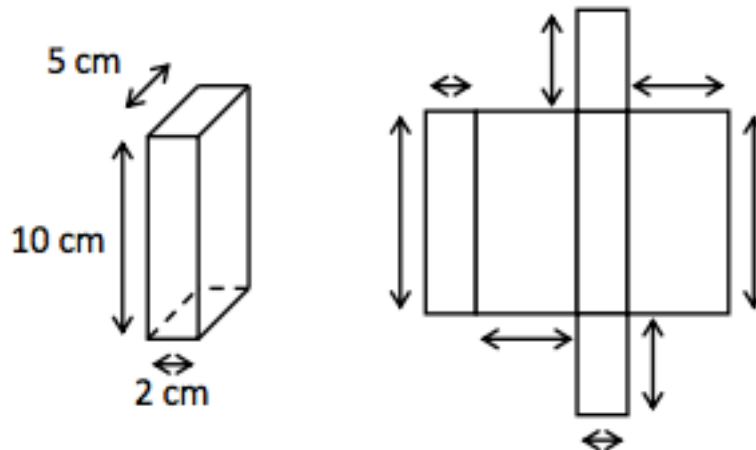

**Exercice 4 : Indique les dimensions manquantes.**



Nom – Prénom : \_\_\_\_\_





# MATHÉMATIQUES

## Géométrie et Espace CM2 - « Je m'entraîne » CORRIGES

Nombre de réussites	14	De 10 à 13	De 4 à 9	< 4
Code de validation				

JE M'ENTRAINE	COMPÉTENCE	CODE
GE12	Je repère et trace des patrons de cube.	

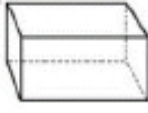
**Exercice 1 : Associe chaque solide à son patron.**

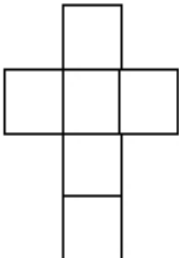
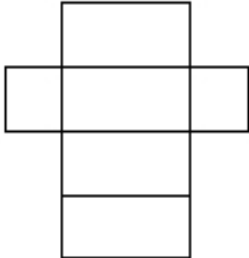
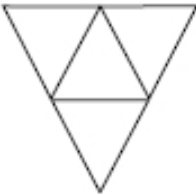
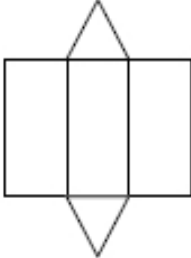
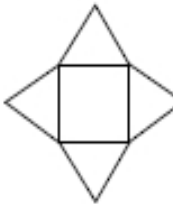
① 	② 	③ 	④ 	⑤ 
La pyramide	Le cube	Le tétraèdre	Le pavé	Le prisme
				
2	4	3	5	1

**Exercice 2 : Aide toi du modèle et complète ce patron de pavé droit.**

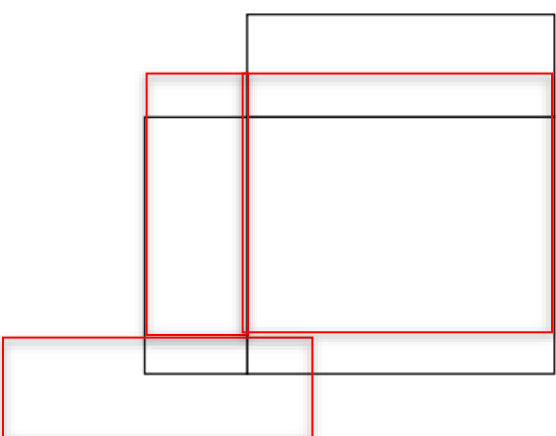



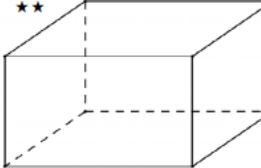

**Exercice 3 : Associe chaque pavé droit à son patron.**

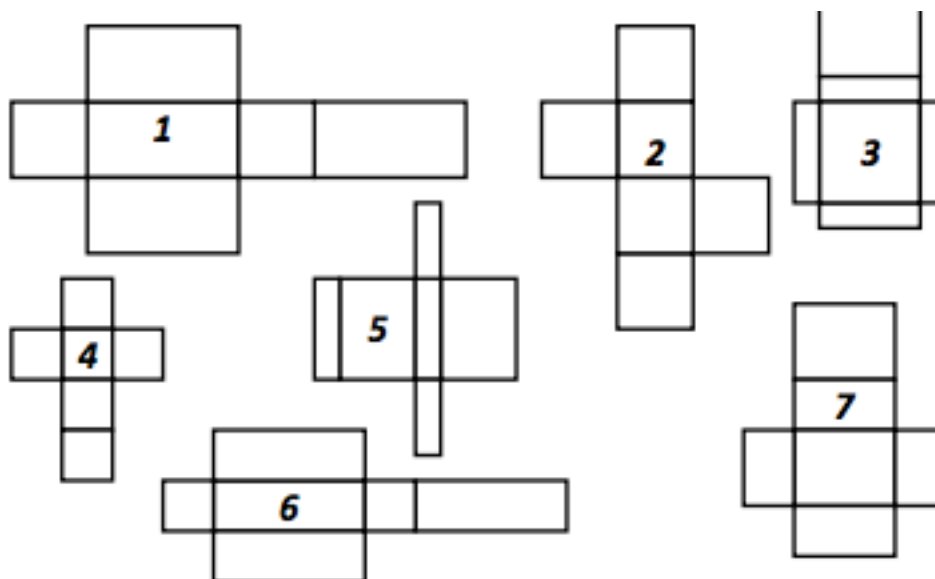

PATRON	b. 1	d. 2	c. 3	g. 4	e. 5	f. 6	a. 7
SOLIDE							

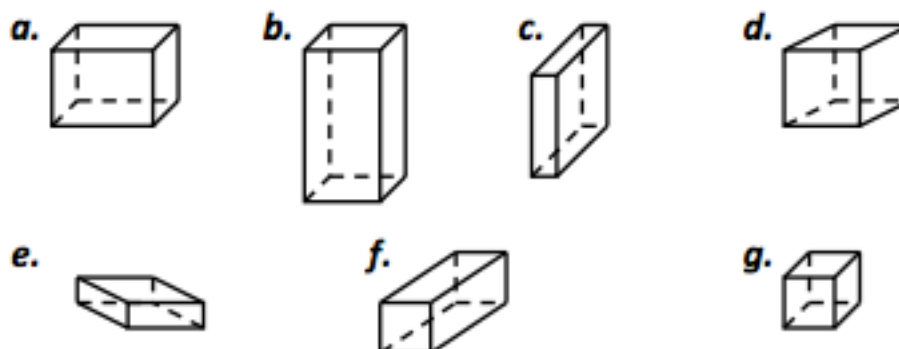

**Exercice 4 : Indique les dimensions manquantes.**

